

**RIVAL**

**Solid Single Burner**

**SB150**



## **Owner's Guide**

**READ AND SAVE THESE INSTRUCTIONS**

# IMPORTANT SAFEGUARDS

When using electrical appliances, basic safety precautions should always be followed to reduce the risk of fire, electric hazard and injury to persons including the following.

1. Read all instructions.
2. Do not touch hot surface. Use handles or knob.
3. To protect against electrical shock, do not immerse cord, plug or appliance in water or other liquid. See instructions for cleaning.
4. Close supervision is necessary when appliance is used by or near children.
5. Do not use appliance unattended.
6. Unplug from outlet when not in use and before cleaning. Turn control knob to OFF before unplugging. Allow to cool before putting on and taking off parts.
7. Do not operate any appliance with a damaged cord or plug or after the appliance malfunctions, or has been damaged in any manner. Return appliance (see warranty) for examination, repair or adjustment.
8. The use of accessory attachments not recommended by the appliance manufacturer may cause injuries.
9. Do not use outdoors.
10. Do not let cord hang over the edge of a table or counter, or touch hot surfaces.
11. Do not place on or near a hot gas or electric burner or in a heated oven.
12. Extreme caution must be used when moving any pot or pan containing hot oil or other liquid from this appliance.
13. To disconnect, turn the control to OFF, then remove plug from the wall outlet.
14. Do not use appliance for other than intended use.

# SAVE THESE INSTRUCTIONS

This appliance is for **HOUSEHOLD USE ONLY**.

No user-serviceable parts inside. Do not attempt to service this product. A short power supply cord is provided to reduce the risk resulting from becoming entangled in or tripping over a longer cord.

An extension cord may be used when care is exercised in its use. When an extension cord is used the marked electrical rating of the extension cord shall be the same or more than the rating of the burner. The extension cord should be arranged so it does not drape over the counter top or table top where it can be pulled on by children or tripped over unintentionally.

## **POLARIZED PLUG**



This appliance has a polarized plug (one blade is wider than the other). To reduce the risk of electric shock, this plug is intended to fit into a polarized outlet only one way. If the plug does not fit fully into the outlet, reverse the plug. If it still does not fit, contact a qualified electrician.

Do not attempt to modify the plug in any way. If the plug fits loosely into the AC outlet or if the AC outlet feels warm, do not use that outlet.

## GET TO KNOW YOUR SINGLE BURNER

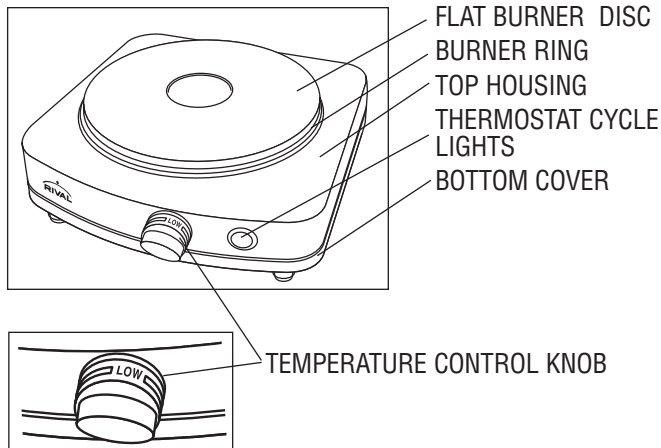

## USING YOUR SINGLE BURNER

1. Make sure the Single Burner is on a level countertop or surface. Be certain that your appliance is resting level on the countertop.
  - Avoid using pots and pans that are unstable and easily tipped.
  - Use pans that are flat with a base no larger than the BURNER DISC.
2. Place pan on BURNER DISC.
3. Turn TEMPERATURE CONTROL KNOB from off to the selected setting.
  - The element will begin heating immediately and the metal surface will become hot.
  - Do not touch while in use.
4. When not in use, unplug and make sure the appliance is OFF. This helps prevent accidental burns.

## TIPS

- Place a lid on your pan to boil water faster.
- Avoid dropping items on the burner disc.

## CLEANING YOUR SINGLE BURNER

Reasonable care will help ensure many years of use from your Single Burner.

1. Always unplug appliance from electrical outlet and allow to cool before cleaning.
2. Use a damp soapy cloth or sponge to clean the burner surface.
  - NEVER IMMERSE IN WATER OR OTHER LIQUIDS.
  - NEVER USE A HARSH ABRASIVE OR STEEL WOOL PAD ON ANY PART OF THE APPLIANCE.
3. Any servicing other than cleaning should be performed by an authorized service center (See SERVICE INSTRUCTIONS).

For more information on your Solid Single Burner and other Rival® appliances, visit our website today at [www.rivalproducts.com](http://www.rivalproducts.com) or call our service number 1-800-557-4825.

## NOTES

## NOTES

---

## SERVICE INSTRUCTIONS

1. Do NOT attempt to repair or adjust any electrical or mechanical functions on this unit. Doing so will void the Warranty.
2. If you need to exchange the unit, please return it in its original carton, with a sales receipt, to the store where you purchased it. If you are returning the unit more than 30 days after the date of purchase, please see the enclosed Warranty.
3. If you have any questions or comments regarding this unit's operation or believe any repair is necessary, please write to our Consumer Service Department or visit our website at [www.rvalproducts.com](http://www.rvalproducts.com).

Sunbeam Products, Inc. d/b/a Jarden Consumer Solutions  
303 NELSON AVENUE  
NEOSHO, MO 64850

---

## 1 YEAR LIMITED WARRANTY

Sunbeam Products, Inc. d/b/a Jarden Consumer Solutions or if in Canada, Sunbeam Corporation (Canada) Limited doing business as Jarden Consumer Solutions (collectively "JCS") warrants that for a period of one year from the date of purchase, this product will be free from defects in material and workmanship. JCS, at its option, will repair or replace this product or any component of the product found to be defective during the warranty period. Replacement will be made with a new or remanufactured product or component. If the product is no longer available, replacement may be made with a similar product of equal or greater value. This is your exclusive warranty. Do NOT attempt to repair or adjust any electrical or mechanical functions on this product. Doing so will void this warranty.

This warranty is valid for the original retail purchaser from the date of initial retail purchase and is not transferable. Keep the original sales receipt. Proof of purchase is required to obtain warranty performance. JCS dealers, service centers, or retail stores selling JCS products do not have the right to alter, modify or any way change the terms and conditions of this warranty. This warranty does not cover normal wear of parts or damage resulting from any of the following: negligent use or misuse of the product, use on improper voltage or current, use contrary to the operating instructions, disassembly, repair or alteration by anyone other than JCS or an authorized JCS service center. Further, the warranty does not cover: Acts of God, such as fire, flood, hurricanes and tornadoes.

### What are the limits on JCS's Liability?

JCS shall not be liable for any incidental or consequential damages caused by the breach of any express, implied or statutory warranty or condition.

Except to the extent prohibited by applicable law, any implied warranty or condition of merchantability or fitness for a particular purpose is limited in duration to the duration of the above warranty.

JCS disclaims all other warranties, conditions or representations, express, implied, statutory or otherwise.

JCS shall not be liable for any damages of any kind resulting from the purchase, use or misuse of, or inability to use the product including incidental, special, consequential or similar damages or loss of profits, or for any breach of contract, fundamental or otherwise, or for any claim brought against purchaser by any other party.

Some provinces, states or jurisdictions do not allow the exclusion or limitation of incidental or consequential damages or limitations on how long an implied warranty lasts, so the above limitations or exclusion may not apply to you.

This warranty gives you specific legal rights, and you may also have other rights that vary from province to province, state to state or jurisdiction to jurisdiction.

### How to Obtain Warranty Service

#### In the U.S.A.

If you have any question regarding this warranty or would like to obtain warranty service, please call 1-800-557-4825 and a convenient service center address will be provided to you.

#### In Canada

If you have any question regarding this warranty or would like to obtain warranty service, please call 1-800-557-4825 and a convenient service center address will be provided to you.

In the U.S.A., this warranty is offered by Sunbeam Products, Inc d/b/a Jarden Consumer Solutions located in Boca Raton, Florida 33431. In Canada, this warranty is offered by Sunbeam Corporation (Canada) Limited doing business as Jarden Consumer Solutions, located at 5975 Falbourn Street, Mississauga, Ontario L5R 3V8. If you have any other problem or claim in connection with this product, please write our Consumer Service Department. **PLEASE DO NOT RETURN THIS PRODUCT TO ANY OF THESE ADDRESSES OR TO THE PLACE OF PURCHASE.**